

Page: Description

- 01: RUBY TOP SHEET
- 02: MULLIGAN
- 03: BB TOP
 - 04: POWER
 - 05: VILMA
 - 06: BETTY
- 07: DIGI
 - 08: RAP
 - 09: MUX
- 10: RF_BB
- 11: CMT_IF
 - 12: SYS_CONN
 - 13: PROD_TEST_PATTERN
 - 14: BATTERY_CONN
 - 15: AUDIO
 - 16: SIM
 - 17: EMU_RAP
 - 18: UI
 - 19: BTFMRD2
 - 20: CAMERA
 - 21: MMC

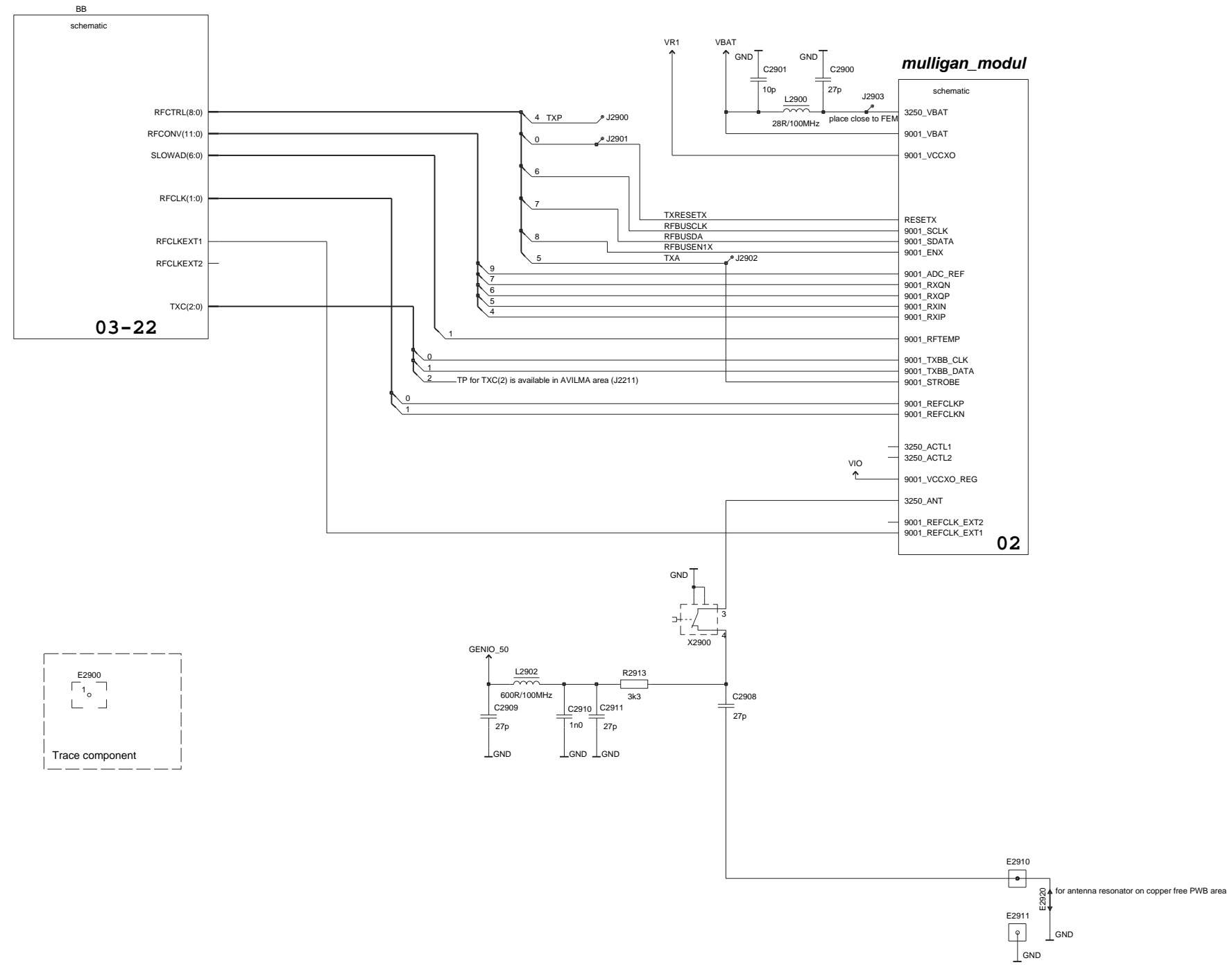

mu3x_04

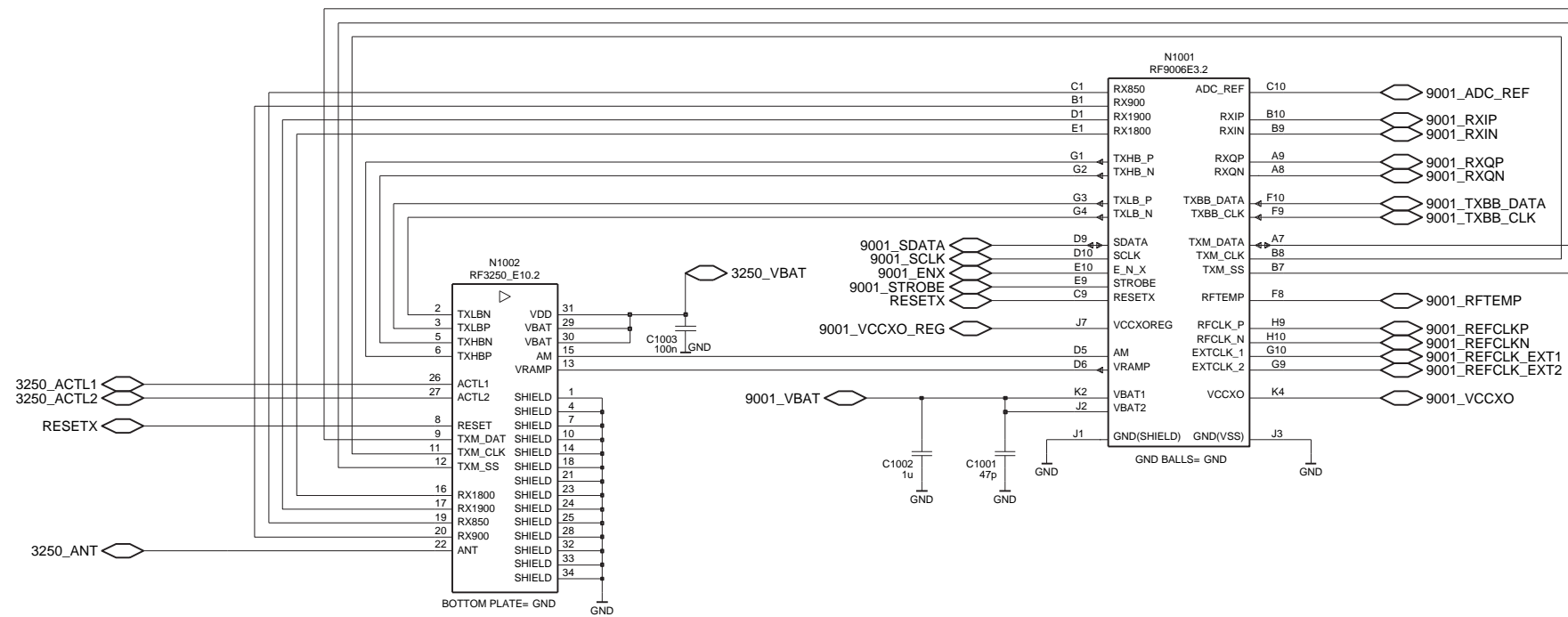

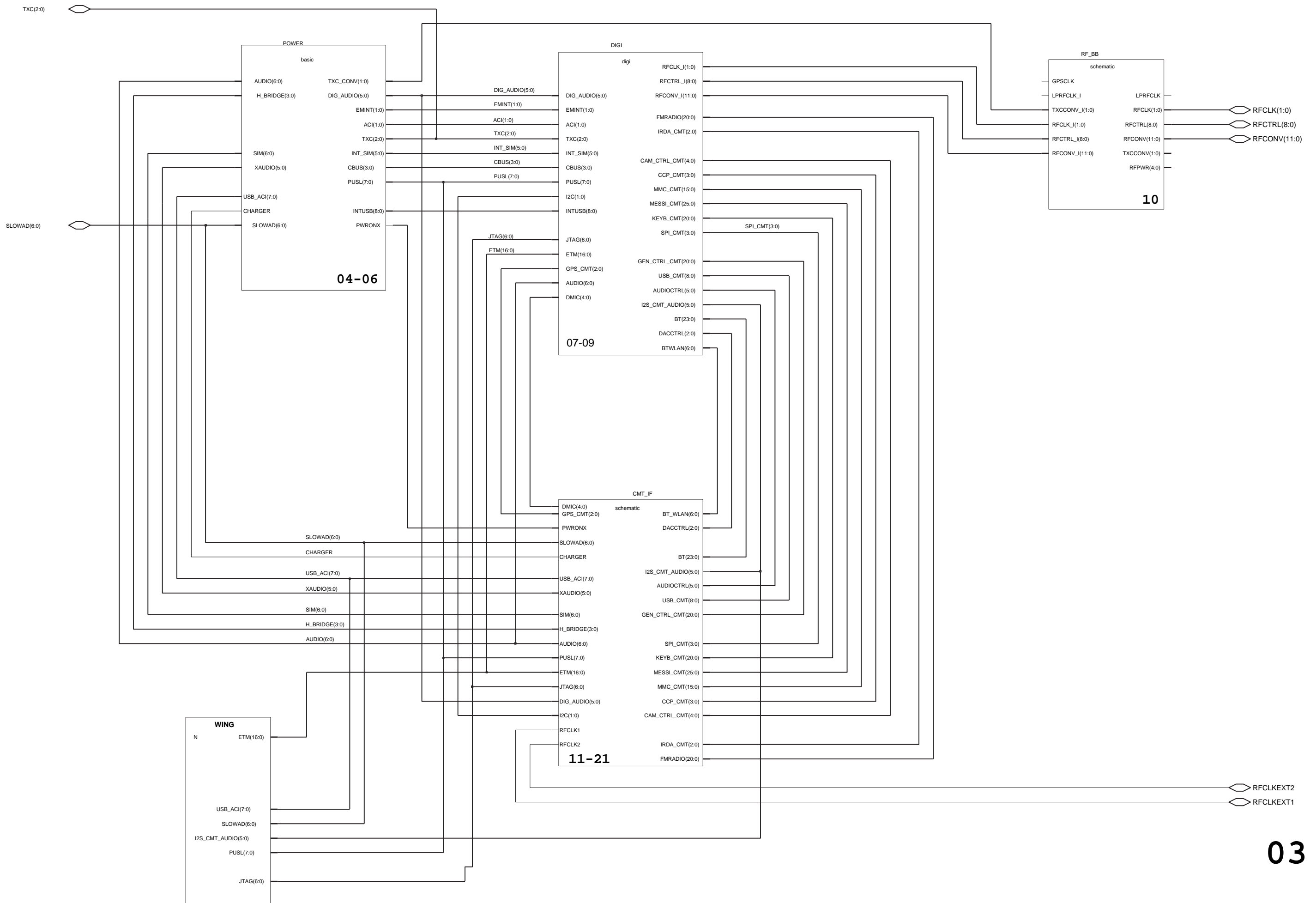

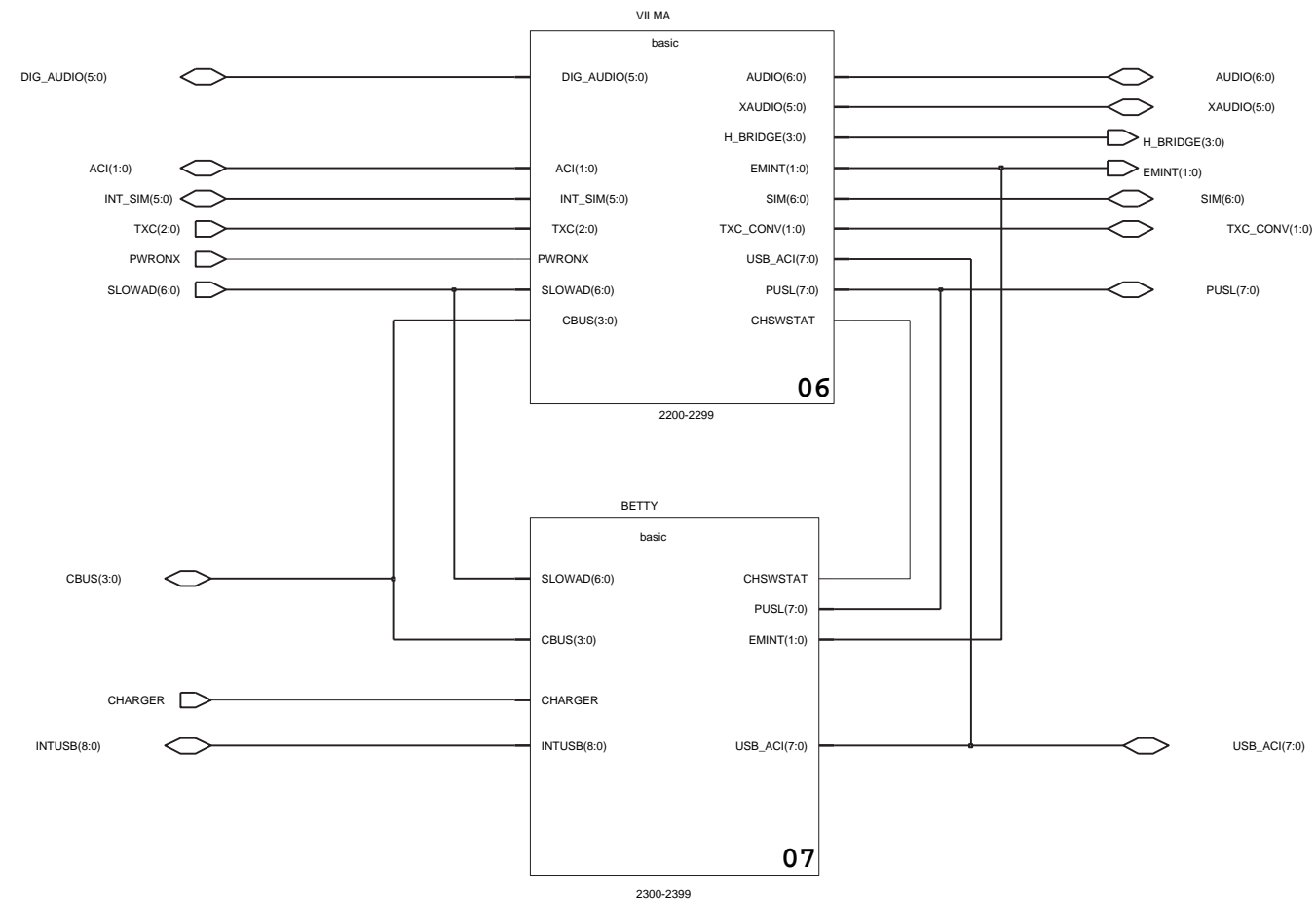

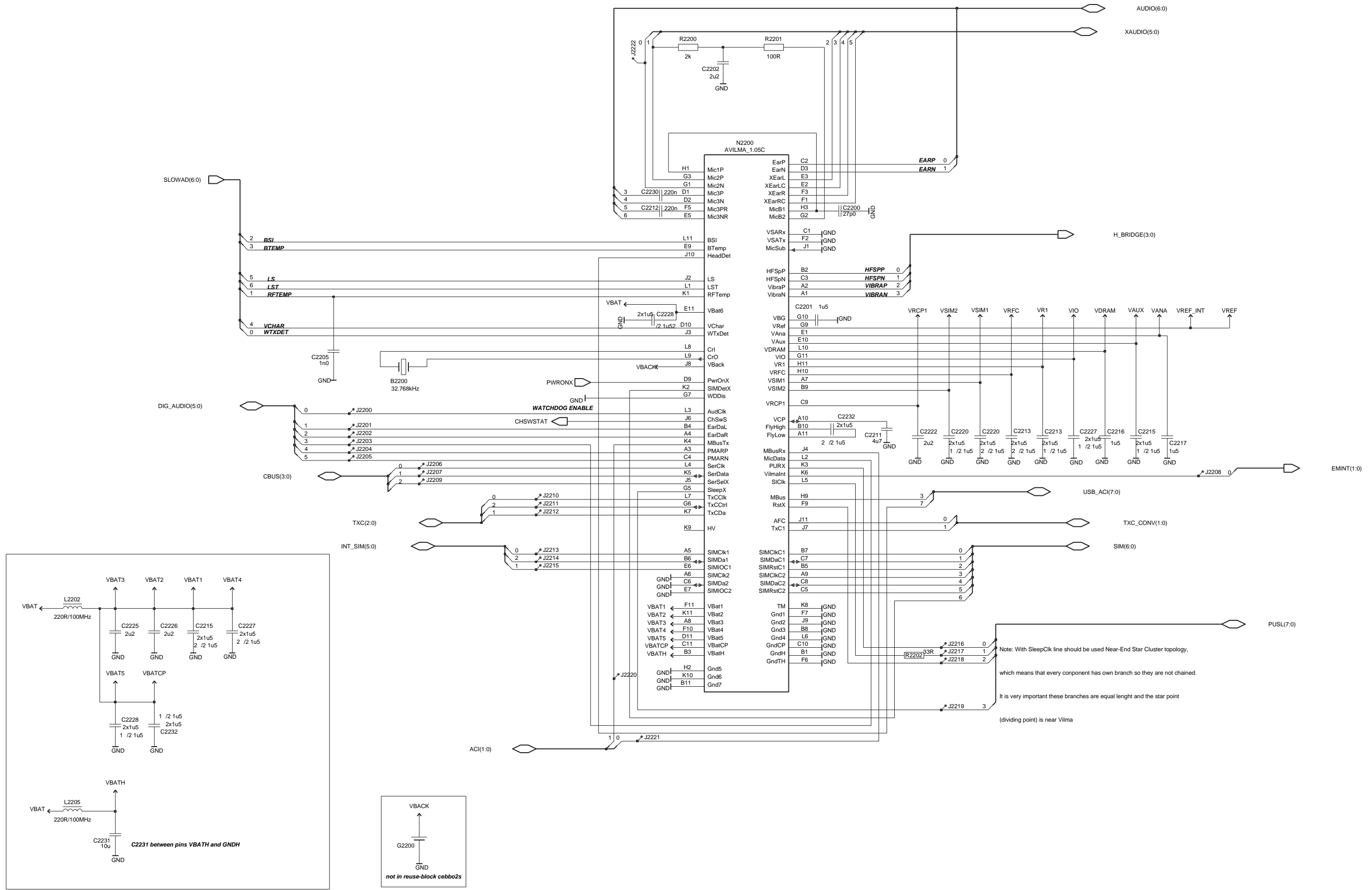

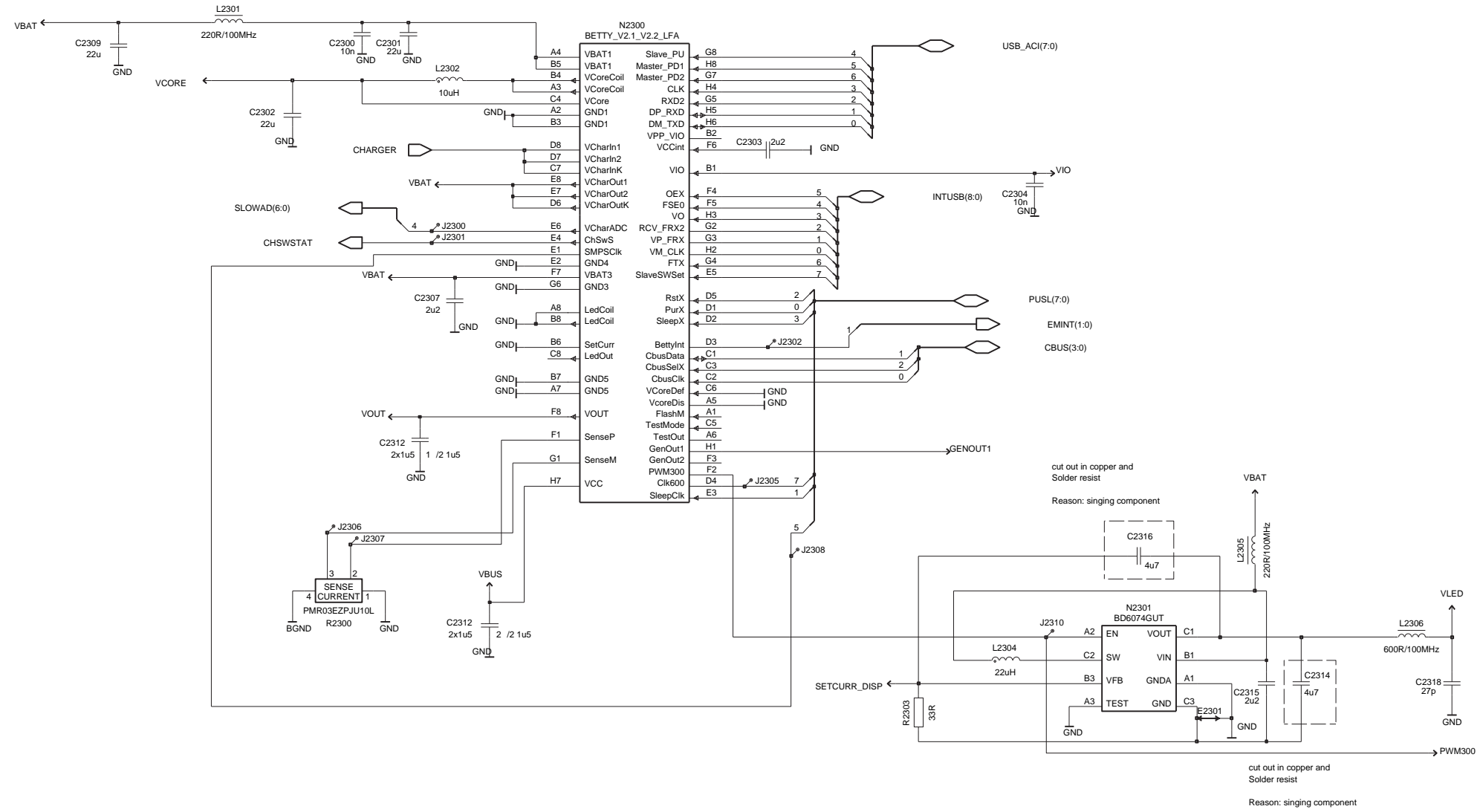

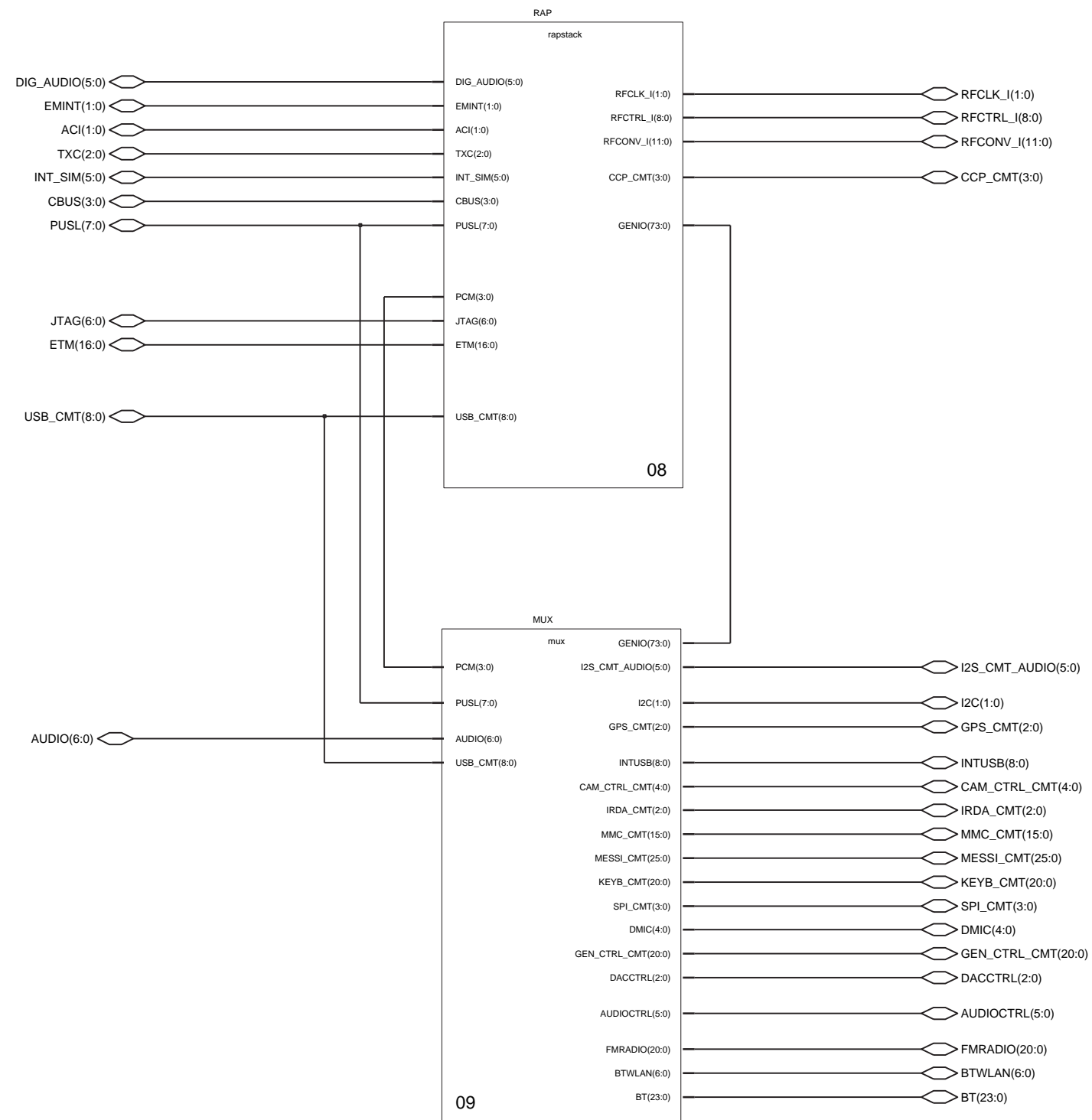

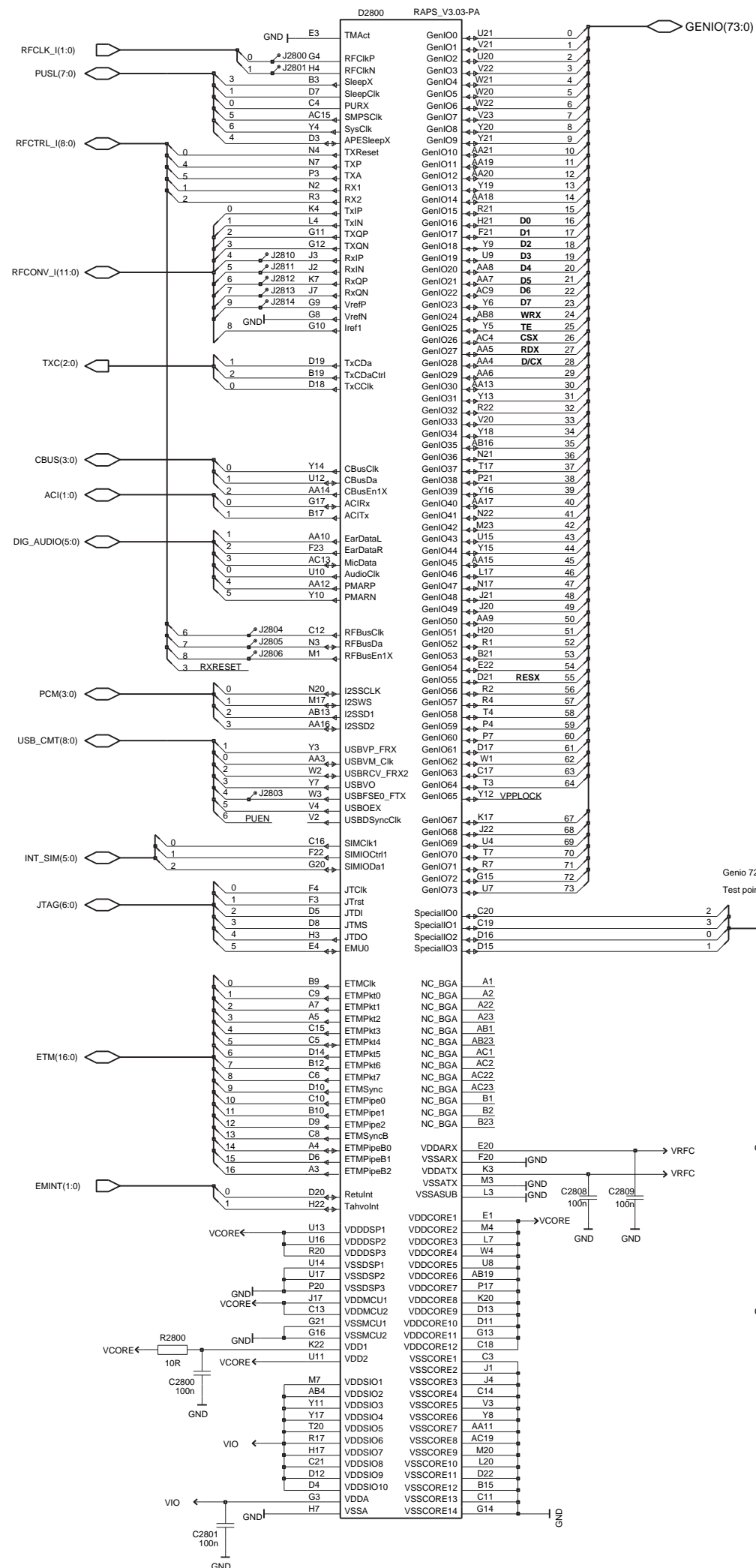

Genio 72, internal or external boot
 Test point for SPI CLK in EMU block

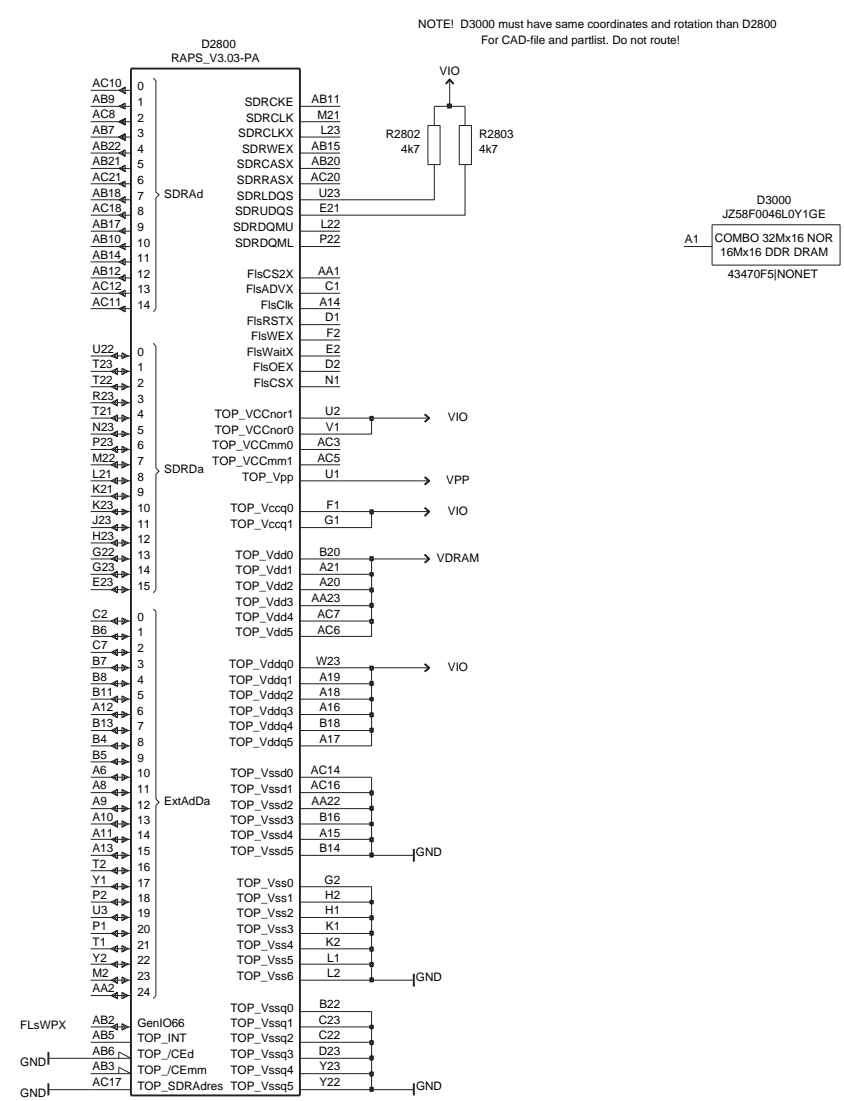
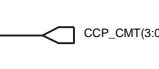

NOTE! D3000 must have same coordinates and rotation than D2800
 For CAD-file and partlist. Do not route!

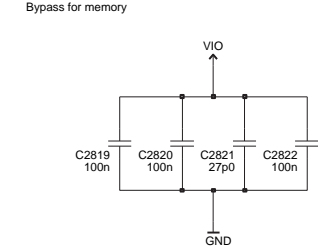
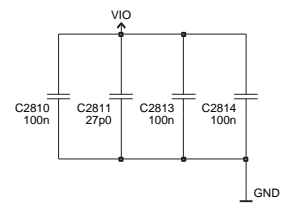
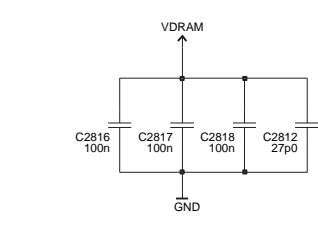
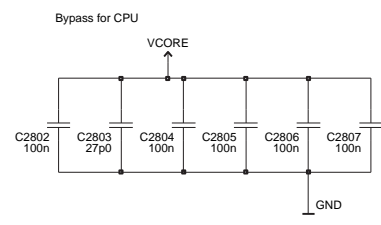
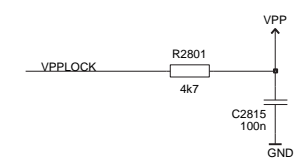
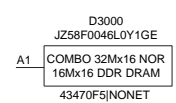

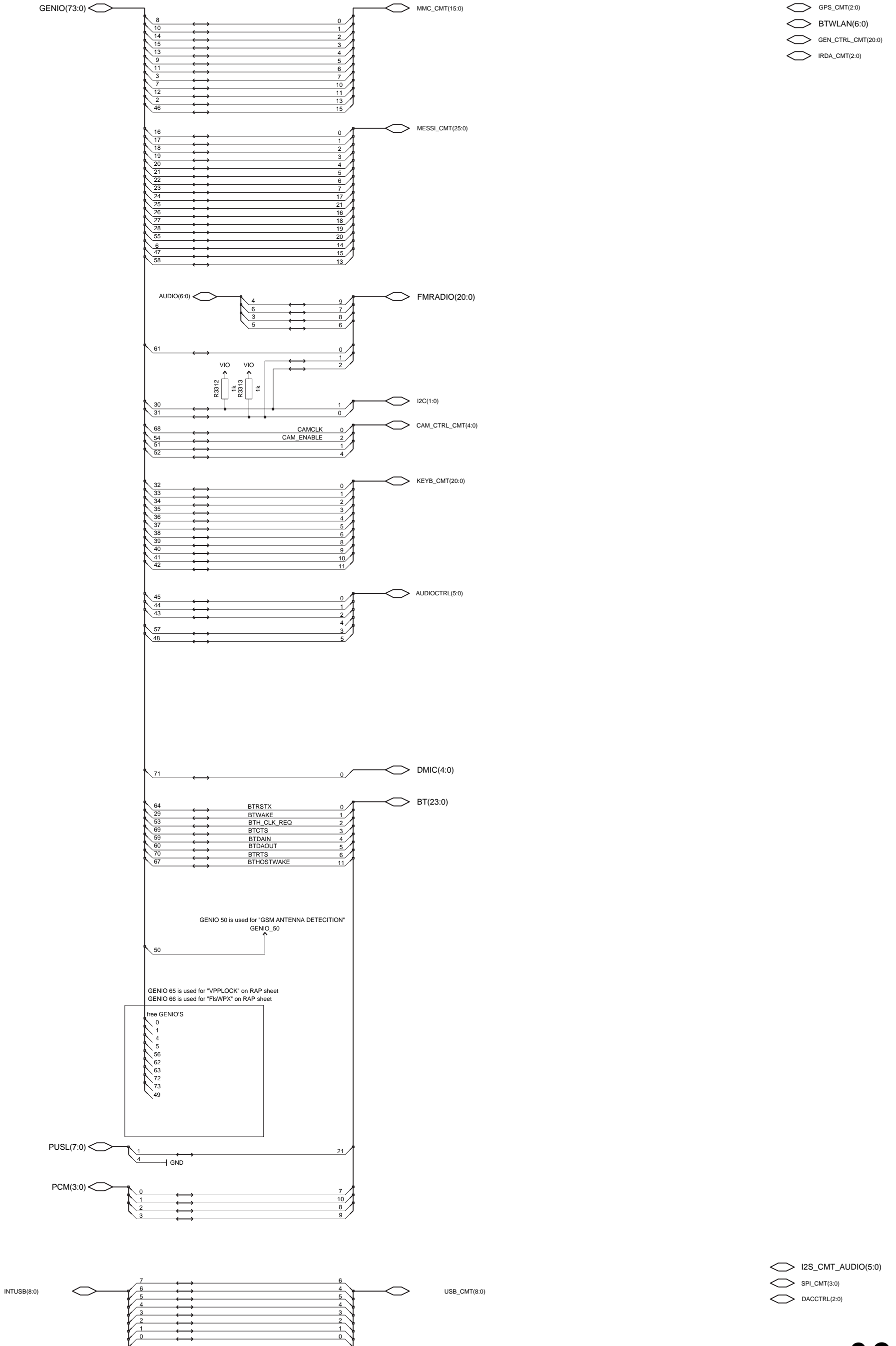

- ⬭ IRDA_CMT(2:0)
- ⬭ USB_CMT(8:0)
- ⬭ GPS_CMT(2:0)
- ⬭ RFCLK2
- ⬭ GEN_CTRL_CMT(20:0)

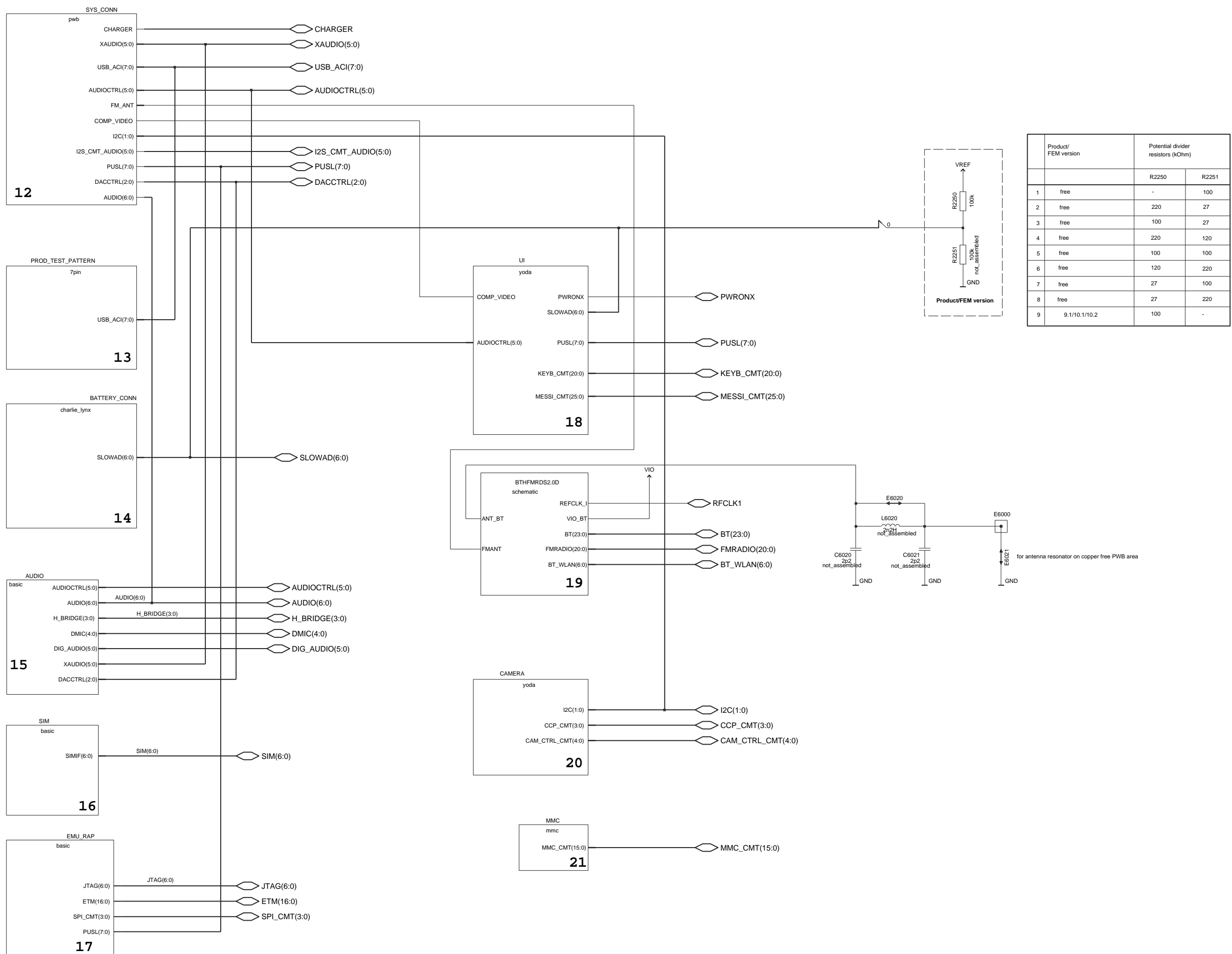

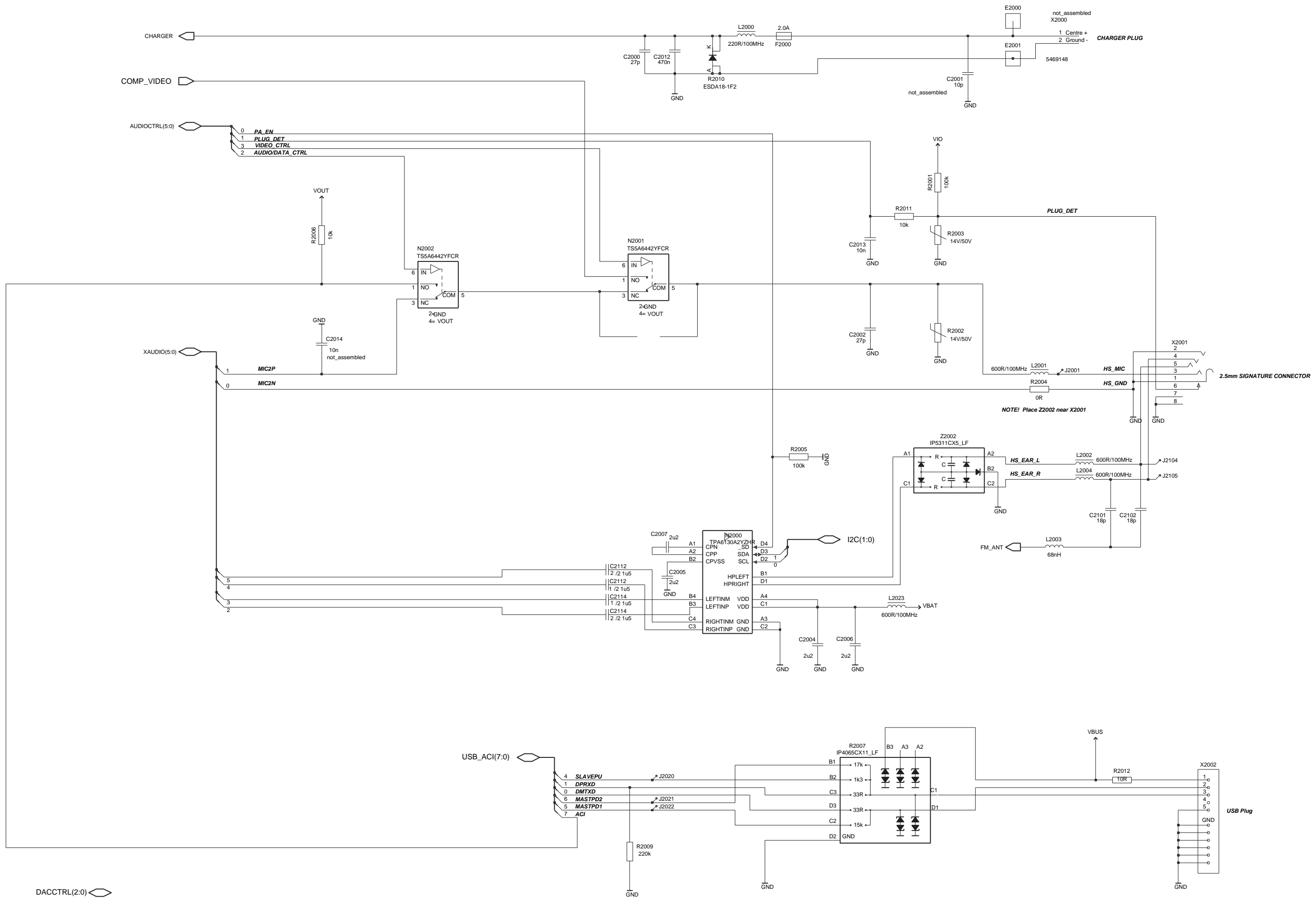

- DACCTRL(2:0)
- I2S_CMT_AUDIO(5:0)
- PUSL(7:0)
- I2C(1:0)
- AUDIO(6:0)

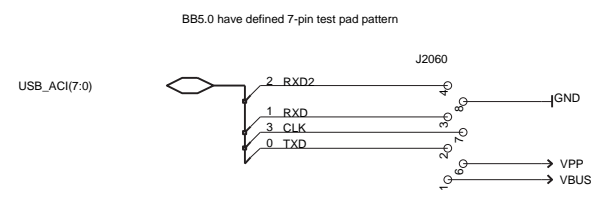

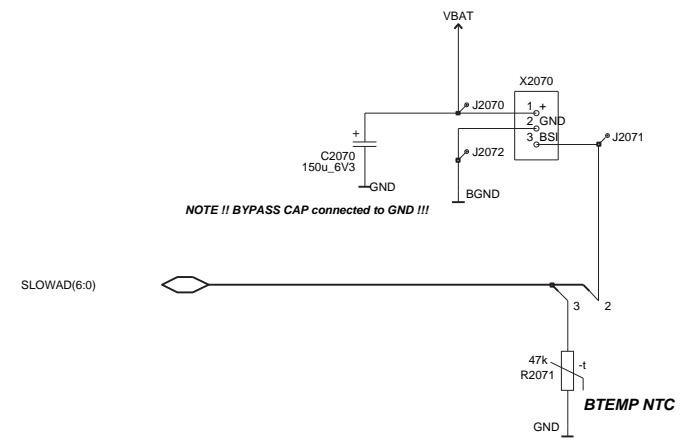

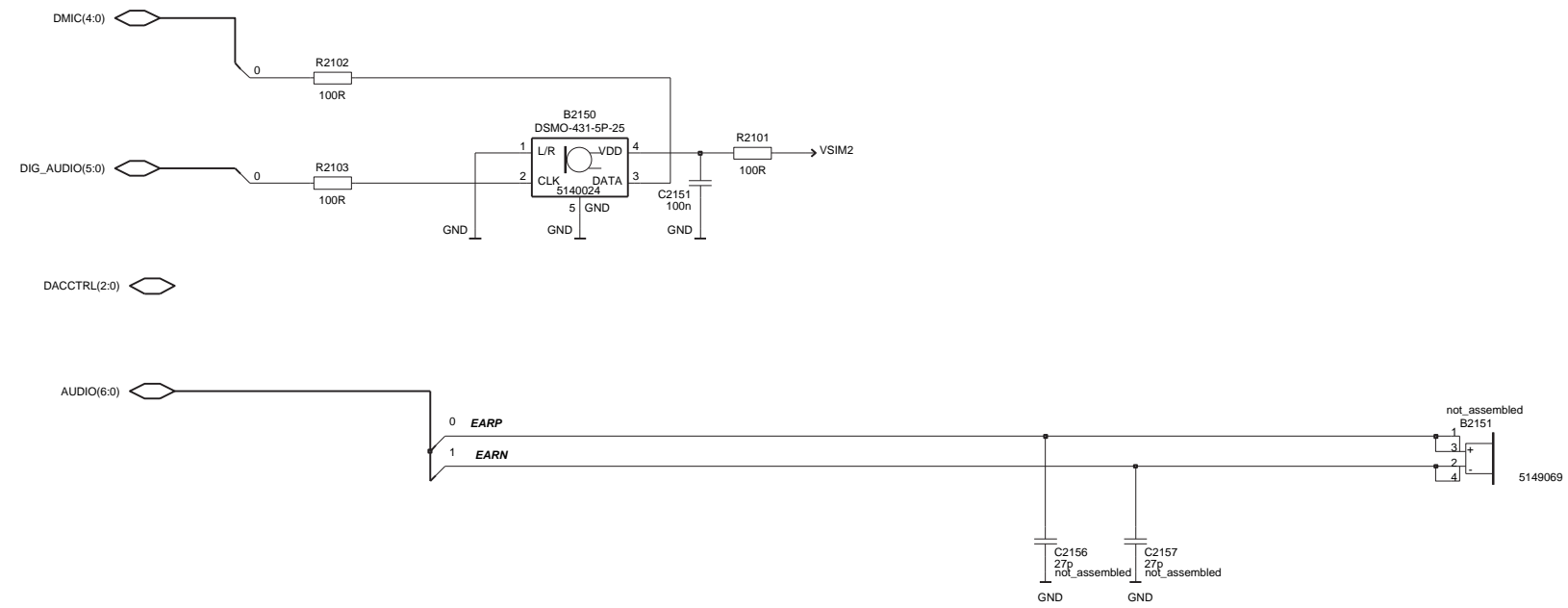

IHF- connection

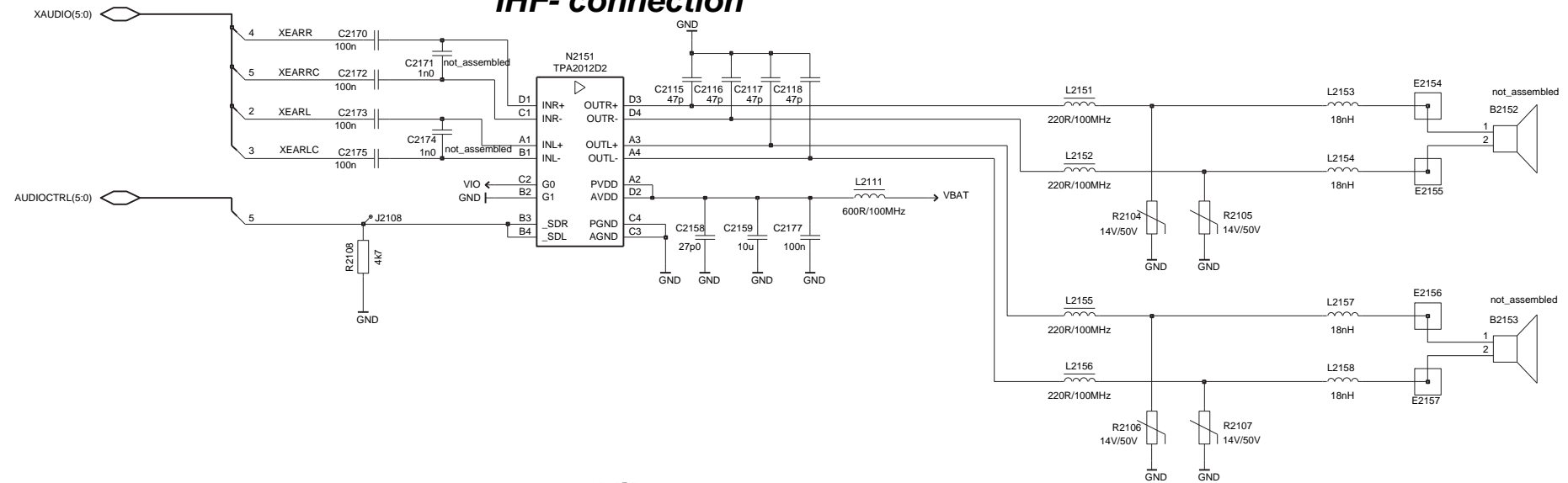

Vibra

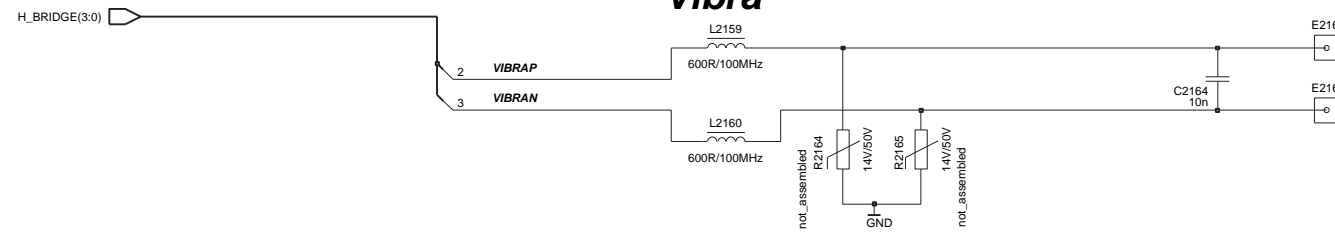

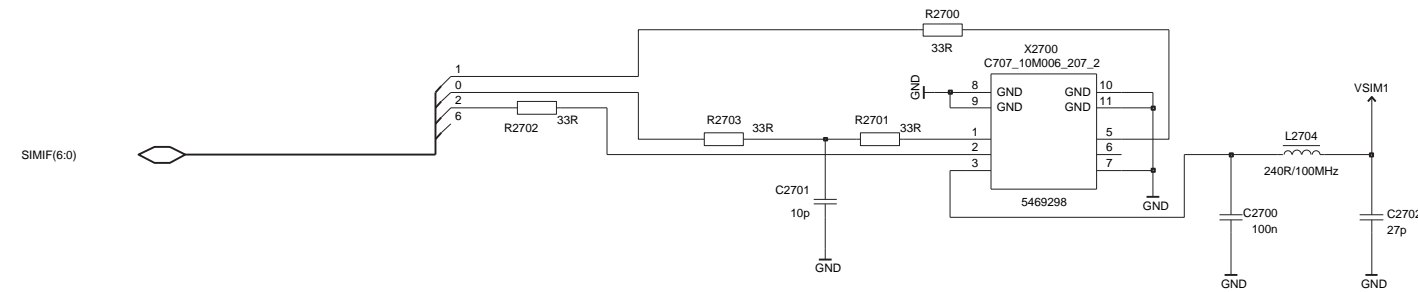

Place = SIM

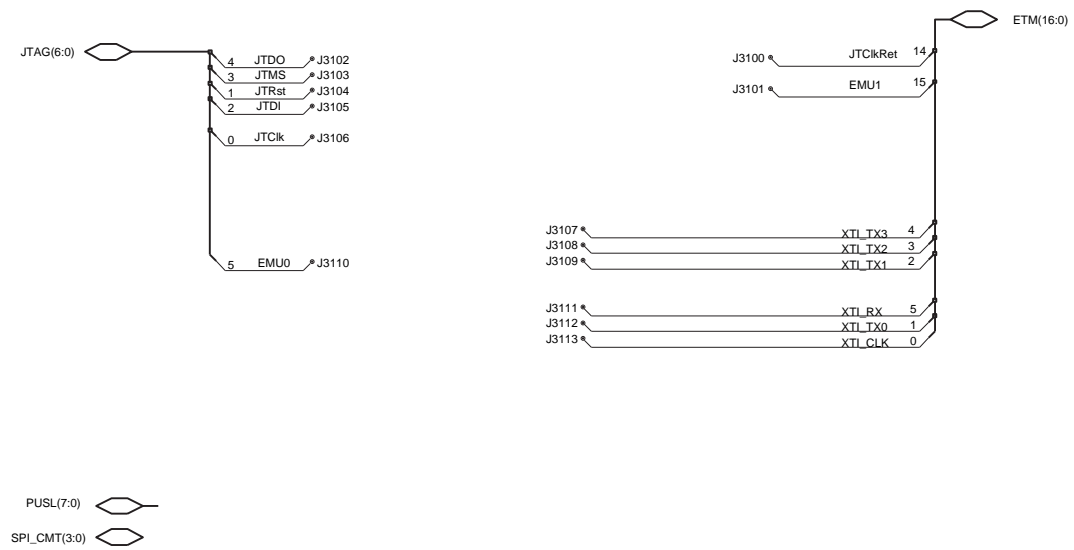

TV OUT

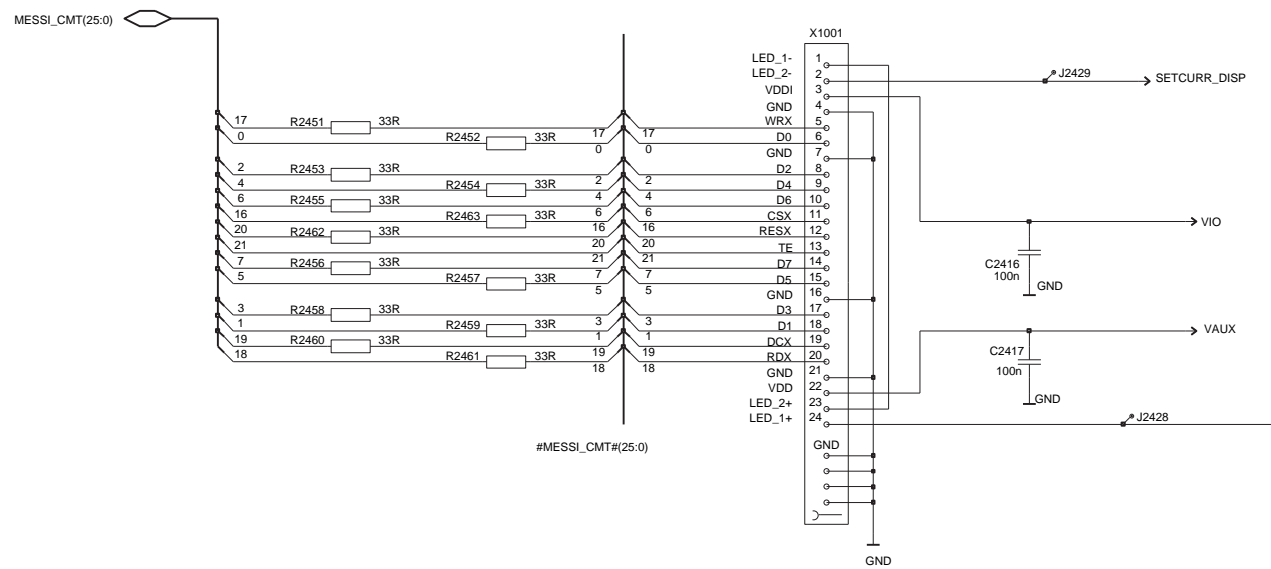
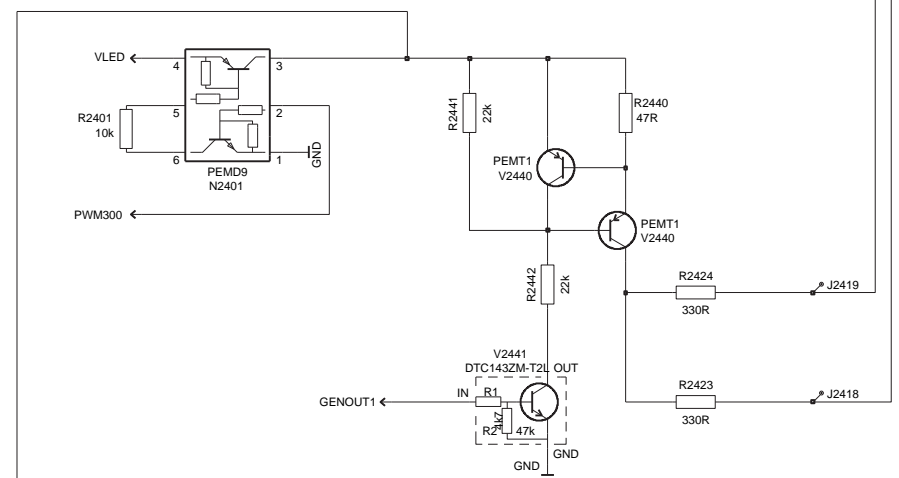
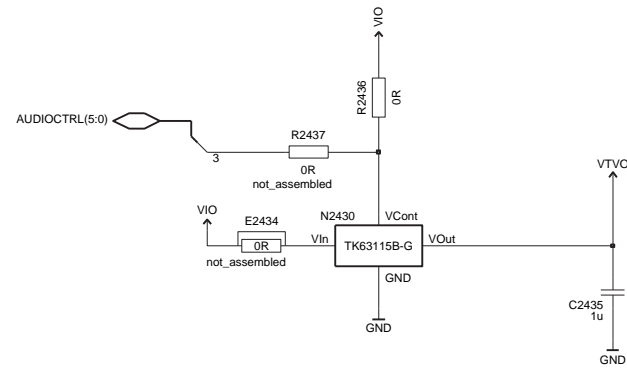
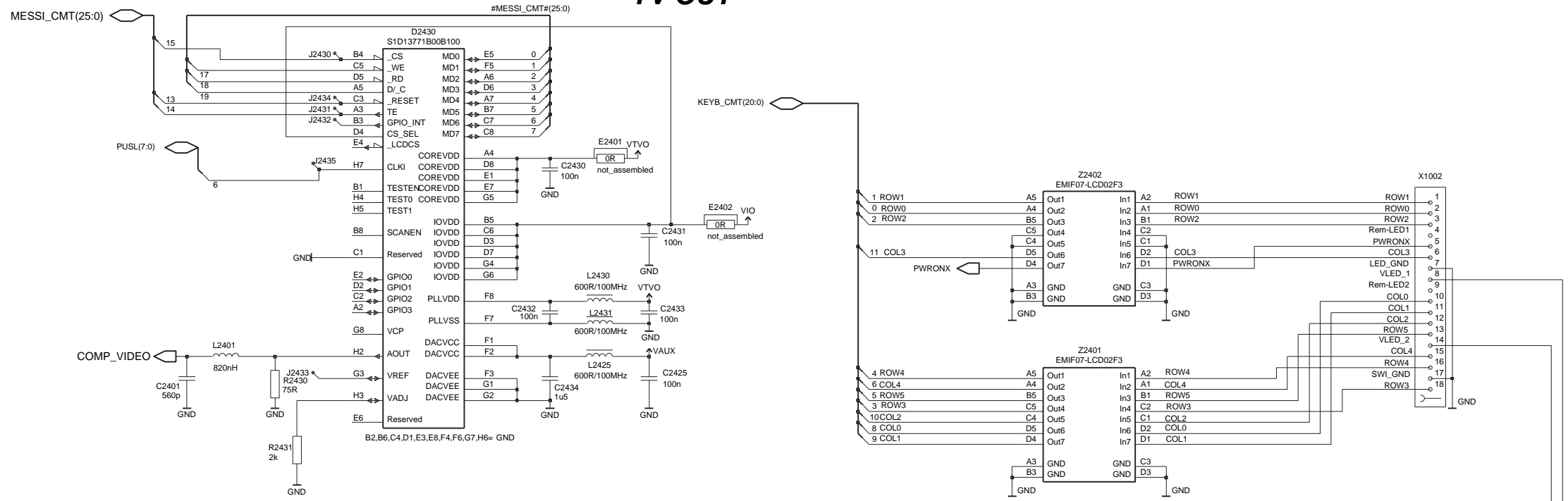

BTHFMRDS_2.0D (2+4+2) A2.0 2007 WK 06 RELEASE
 BLUETOOTH & FM RADIO DISCRETE

